

# INSTRUCTION MANUAL

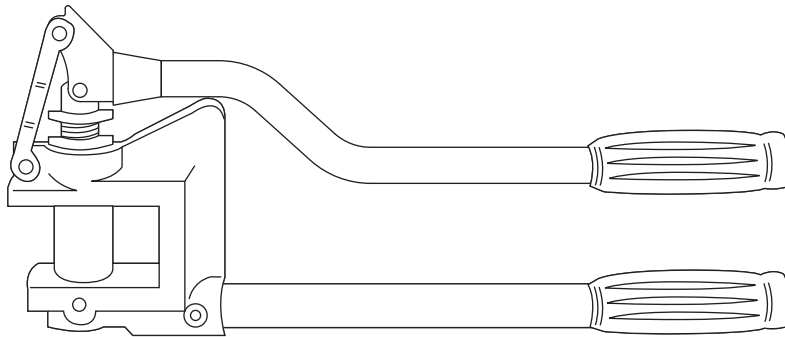

## 709 and 710 Stud Punches



**Read and understand** all of the instructions and safety information in this manual before operating or servicing this tool.

Register this product at [www.greenlee.com](http://www.greenlee.com)

## IMPORTANT SAFETY INFORMATION



### SAFETY ALERT SYMBOL

This symbol is used to call your attention to hazards or unsafe practices which could result in an injury or property damage. The signal word, defined below, indicates the severity of the hazard. The message after the signal word provides information for preventing or avoiding the hazard.

### ⚠ DANGER

Immediate hazards which, if not avoided, **WILL** result in severe injury or death.

### ⚠ WARNING

Hazards which, if not avoided, **COULD** result in severe injury or death.

### ⚠ CAUTION

Hazards or unsafe practices which, if not avoided, **MAY** result in injury or property damage.

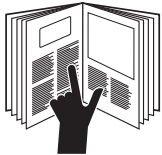

### ⚠ WARNING

Read and understand all of the instructions and safety information in this manual before operating or servicing this tool.

Failure to observe this warning could result in severe injury or death.



### ⚠ WARNING

Electric shock hazard:

This is not an insulated tool. Contact with live circuits could result in severe injury or death.

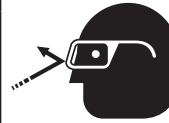

### ⚠ WARNING

Wear eye protection when using this tool.

Failure to wear eye protection could result in serious eye injury from flying debris.

### ⚠ CAUTION

Do not add extensions (cheaters) to the handles. Using excessive force may result in injury or damage to the tool. If excessive force is required to complete a punch, verify that the type and thickness of material do not exceed the capacity of the tool.

### ⚠ CAUTION

- Inspect the tool prior to use. Replace worn, damaged or missing components with Greenlee replacement parts. A damaged or improperly assembled tool may break.
- Use this tool for manufacturer's intended use only. Use other than that which is described in this manual may result in injury or damage to the tool.

### IMPORTANT

Do not use on heavier than 20 gauge mild steel.

All specifications are nominal and may change as design improvements occur. Greenlee Textron Inc. shall not be liable for damages resulting from misapplication or misuse of its products.

## KEEP THIS MANUAL

## Description

Greenlee Stud Punches are intended to punch round holes in 20 gauge steel studs. The 709 tool punches a 22.5 mm (7/8") diameter hole; the 710 tool punches a 34.1 mm (1-11/32") hole.

## Safety

Safety is essential in the use and maintenance of Greenlee tools and equipment. This manual and any markings on the tool provide information for avoiding hazards and unsafe practices related to the use of this tool. Observe all of the safety information provided.

## Purpose of this Manual

This manual is intended to familiarize all personnel with the safe operation and maintenance procedures for the following Greenlee tools:

709 Stud Punch  
710 Stud Punch

Keep this manual available to all personnel.

Replacement manuals are available upon request at no charge at [www.greenlee.com](http://www.greenlee.com).

## Operation

Position the punch on the metal stud. Squeeze the handles together. The slug will fall free when the hole is complete.

*Note: This tool will punch to its rated capacity with approximately 56 pounds of handle force. If excessive force is required, stop and inspect the tool and the material.*

## Bushings

Bushings are available for the holes punched by the Stud Punches. Bushings protect wire insulation from the sharp edges of the metal stud.

- Use Greenlee 711 Bushings for 22.5 mm (7/8") holes made by the 709 Stud Punch.
- Use 712 Bushings for 34.1 mm (1-11/32") holes made by the 710.

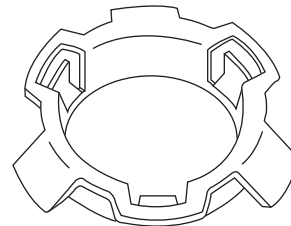

## Maintenance

Lubricate all moving parts with a lightweight oil.

To replace the punch, refer to the illustration on the next page, and follow this procedure:

1. Remove the locknut (A) from the pivot bolt (B), and then remove the pivot bolt from the punch holder (8).
2. Remove the entire punch holder shaft and sleeve from the C-frame.
3. Depress the sleeve and unscrew the punch from the punch holder.

**Illustration**

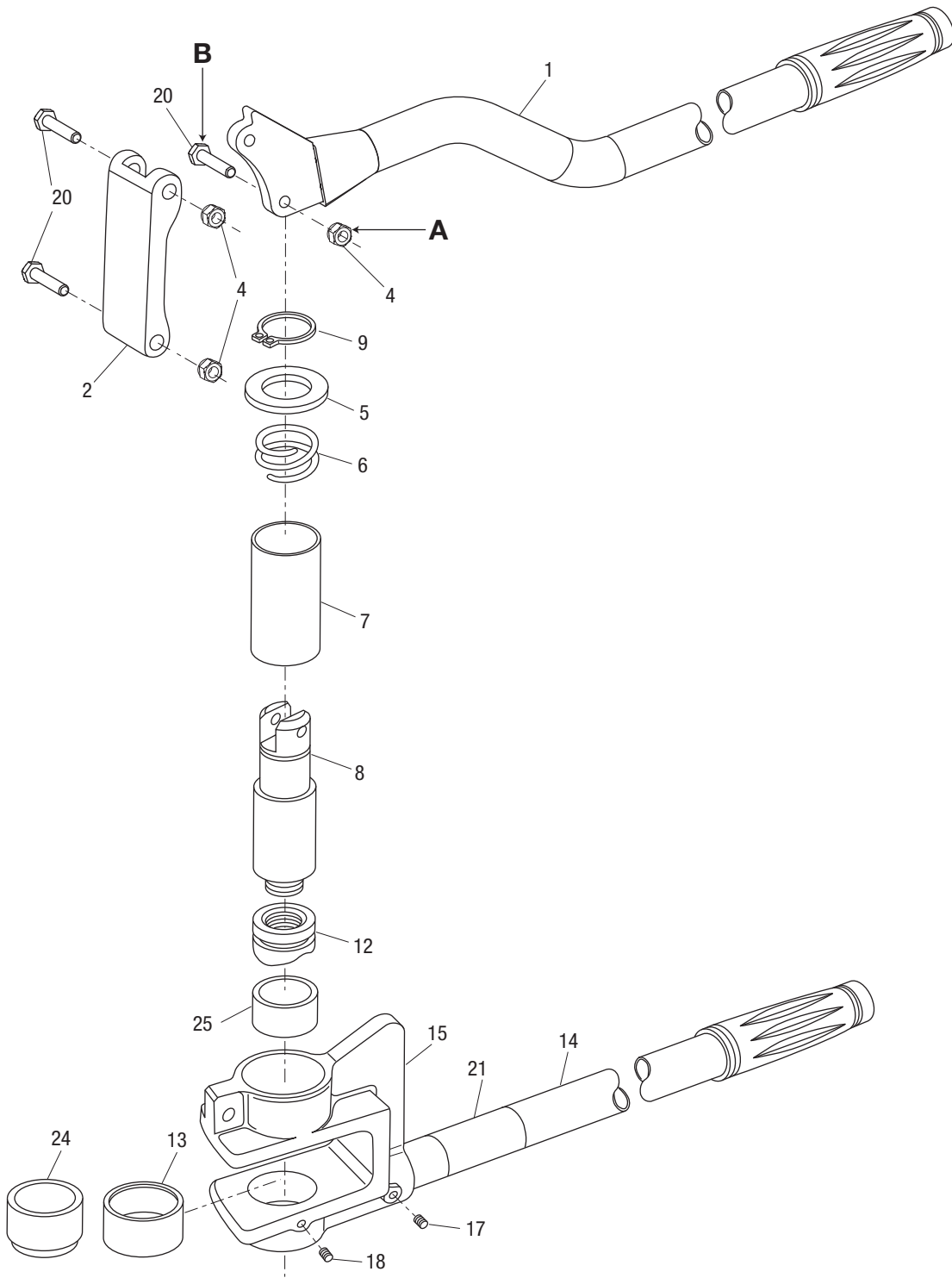

**Parts List**

Key	Part No. 709	Part No. 710	Description	Qty.
	50222805	50212850	Stud punch complete	
1			Lever unit.....	1
2			Link (see below for service parts).....	1
4			Locknuts, nylon 1/4-20 grade 5 .....	3
5	50213032	50213032	Washer, flat .968 x 1.62 x .062 .....	1
6	50215574	50215574	Spring, compression .....	1
7	52026024	52026024	Sleeve.....	1
8	50222821	50212966	Holder, punch .....	1
9	90513614	90513614	Retaining ring, .865 Truarc #5100-93-S-PP .....	1
12	51040060	50248235	Punch, conduit .....	1
13	50222864	50212974	Die .....	1
14	52027490	52027490	Handle, green .....	1
15			C-Frame unit .....	1
17	90507649		Screw, set, 1/4-20 x .375 socket w/locking patch.....	2
17		90507649	Screw, set, 1/4-20 x .375 socket w/locking patch.....	1
18		90506170	Screw, set, 1/4-20 x .250 socket w/locking patch.....	1
20			Bolts, pivot, 1/4-20 x 1.25 grade 5.....	3
21	50053809	50010085	Decal, identification .....	1
24	52024666	—	Bushing, die.....	1
25	50213016	50213016	Bushing .....	1

**Repair Kits List**

Part No.	Description
<b>709 and 710</b>	
50060155	Pin kit (includes items 4 and 20)
50059327	Link kit (includes items 2, 4, and 20)
50309684	Lever and link kit (includes items 1, 2, 4, and 20)
<b>710 Only</b>	
** 52026022	Sliding mechanism service kit (includes items 7 and 8)
<b>709 Only</b>	
* 52026024	Sleeve (O.D. = 1.435") (includes item 7)
* 50222848	Service sleeve (O.D. = 1.110")
** 50222821	Punch holder

\* Check O.D. for correct sleeve size.

\*\* Use one flat washer (50213032), as shown in the illustration, when replacing the punch holders.



4455 Boeing Drive • Rockford, IL 61109-2988 • USA • 815-397-7070  
An ISO 9001 Company • Greenlee Textron Inc. is a subsidiary of Textron Inc.

[www.greenlee.com](http://www.greenlee.com)

**USA** Tel: 800-435-0786  
Fax: 800-451-2632

**Canada** Tel: 800-435-0786  
Fax: 800-524-2853

**International** Tel: +1-815-397-7070  
Fax: +1-815-397-9247